

MICRO DIFFERENTIAL PRESSURE SWITCH MODEL DPS52



1)DPS52 front view 2)DPS52 bottom view 3)DPS52 upper part view

The DPS52 is an adjustable differential pressure switch capable of detecting miniscule changes in pressure due to the size and proven design. The switch set point or switching point can be field adjustable without the need of a manometer by simply using the adjustment knob and the built in calibrated visual scale. This switch is equipped a clear cover that not only protects the adjustment knob to be move involuntary but also provides class IP54 protection.

Features

- Sense the slight change of pressure, suitable for HVAC systems
- Automatic reset function
- Widely used in wards, laboratories, clean workshops and so on

Technical parameter

General

Basic information

Pressure difference range	20...200-5000Pa
Process connection	The inner and outer diameter of the plastic pipe can be selected
Terminal block	6.35*0.8 AMP standard flat insert
Tests / Admissions	UL60730

Electrical overview

Switching load	1.5A(0.4A) at 250VAC
Resistive(inductive)	0.1A at 24VDC
Initial contact resistance	<100 milliohms

Installantion arrangement

Installation torque	0.8N*M
---------------------	--------

Factory set

Vertical,

pressure connections facing downwards

Operating conditions

Medium Air,non flammable
or non hazardous gases

Temperature Medium:-20...+85°C[-4...+185°F]

Ambient:-40...+85°C[-40...+185°F]

IP grade

IP54 (with cover)

Contact version

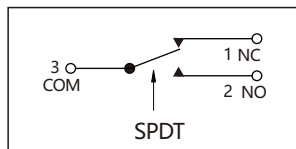

Dimensiones in mm(in)

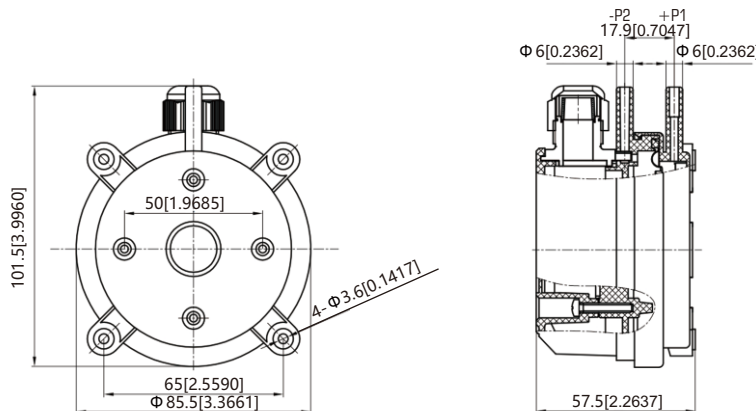

Ordering information

Example part number:DPS52

Name	Model	Differential Pressure Range	Return Difference	Tolerance
DPS52	02	20...200Pa	10±3Pa	15%
	03	30...300Pa	10±3Pa	15%
	04	40...400Pa	20±4Pa	15%
	05	50...500Pa	20±4Pa	15%
	10	200...1000Pa	100±15Pa	15%
	25	500...2500Pa	150±15Pa	15%
	11	100...1000Pa	50±5Pa	15%
	50	1000...5000Pa	250±25Pa	15%
	03A	20...300Pa	10±3Pa	15%
	05A	30...500Pa	20±4Pa	15%
	06A	40...600Pa	20±4Pa	15%
	06	60...600Pa	20±4Pa	15%
	15	100...1500Pa	50±5Pa	15%
	20	200...2000Pa	100±10Pa	15%
45	500...4500Pa	250±25Pa	15%	

Note: The default accessories are a pipette, air tube (1.5m default length), and optional bracket.
1bar=100kPa=0.1MPa=14.5psi
Please make separate remarks for special requirements.